

LOTEM 800V

SITE PREPARATION GUIDELINES



OPEN TO A WORLD OF COLOR



IMPORTANT NOTICE

This document is delivered subject to the following conditions and restrictions:

This document contains proprietary information of Scitex Corporation Ltd.

Such information is hereby supplied solely for the purpose of assisting explicitly and properly authorized users of Scitex systems in the proper operation of Scitex equipment.

Without the express prior written permission of Scitex, no part of the contents hereof may be used for any other purpose, disclosed to any person or firm, or reproduced by any means.

The text and drawings herein are for the purposes of illustration and reference only.

The specifications on which they are based are subject to change without notice.

Catalog No. 399Z51191C
Copyright © 1998
by Scitex Corporation Ltd.
All Rights Reserved

First edition: January 1998

Second edition: February 1998

Third edition: November 1998

US Patents

This product is covered by one or more of the following US patents:

4.350.996	4.365.256	4.456.924	4.500.919	4.834.520	4.853.709	4.897.737	4.931.637
4.992.862	5.079.721	5.103.407	5.111.308	5.113.249	5.119.440	5.122.871	5.124.547
5.150.225	5.153.769	5.155.782	5.157.516	5.200.816	5.208.888	5.221.997	5.227.895
5.247.174	5.247.352	5.283.140	5.285.297	5.296.935	5.299.020	5.313.278	5.323.248
5.325.217	5.328.032	5.331.439	5.333.064	5.339.176	5.343.059	5.355.446	5.359.458
5.367.388	5.384.648	5.384.899	5.412.491	5.412.737	5.420.702	5.473.733	5.481.379
5.488.906	5.497.252	5.508.828	5.509.561	5.519.792	5.519.852	5.526.107	5.526.143
5.532.728	5.561.691	5.568.595	5.576.754	5.579.115	5.592.309	5.594.556	5.600.448
5.608.822	5.615.282	5.623.001	5.636.330	5.649.220	5.650.076	5.652.804	5.691.823
5.691.828	5.696.393	5.699.174	5.708.736	5.739.819	5.742.743	5.764.381	5.813.346

Trademarks

Scitex, the Scitex logo, and Lotem 800V are trademarks of Scitex Corporation Ltd. or its wholly-owned subsidiaries and may be registered in certain jurisdictions.



LOTEM 800V SITE PREPARATION GUIDELINES

Dear Customer:

Please take a few moments to read through this document.

This document provides guidelines for preparing your site for the **Lotem 800V** Platesetter installation.

Work together with your Scitex service engineer to ensure that you have all the required details. Proper preparation of your site will help to prevent unnecessary problems and delays when installing the **Lotem 800V**.

The following topics are discussed:

- Pre-installation checklist; the checklist summarizes, in a table format, the various topics discussed in this document. Review this checklist to ensure that you have prepared and considered all the necessary requirements.
- Floor space requirements
- **Lotem 800V** site dimensions
- Weight requirements
- Electrical requirements
- Environmental conditions
- Other conditions
- Network/modem requirements
- Processor specifications
- Plates
- Appendix A summarizes the customer configuration requirements.

Two punch configuration order forms are also provided in this kit:

- Standard Punch Configurations
- Punch and Plate Configuration Order form

The two (2) forms should be filled out and returned to your Scitex representative.

Pre-installation Checklist

Before arrival of the **Lotem 800V** at your site, you should prepare a final layout of the installation site and make sure that all requirements are met. Use the following table that lists the necessary pre-installation items.

	Requirement Item	Page	Done ?
1.	Adequate space according to the customer configuration	5, 11 (Table 1)	<input type="checkbox"/>
2.	Access to and operation of the Lotem 800V	5	<input type="checkbox"/>
3.	Fork lift to lift the packaging and the Platesetter	5	<input type="checkbox"/>
4.	Electrical requirements	6	<input type="checkbox"/>
5.	Voltage settings	6	<input type="checkbox"/>
6.	Power cable connectors	6	<input type="checkbox"/>
7.	Power line disturbances	7	<input type="checkbox"/>
8.	Grounding	7	<input type="checkbox"/>
9.	Cable routing provisions, according to the distances between the equipment at your site	7	<input type="checkbox"/>
10.	Environmental conditions	8	<input type="checkbox"/>
11.	Cleanliness	8	<input type="checkbox"/>
12.	Static electricity	8	<input type="checkbox"/>
13.	Humidity	8	<input type="checkbox"/>
14.	Air conditioning	8, 12 (Table 2)	<input type="checkbox"/>
15.	Yellow safe light (for Kodak green plate requiring preheating).	9	<input type="checkbox"/>
16.	Thermometers and humidity meters/records - recommended.	9	<input type="checkbox"/>
17.	Air compressor	9	<input type="checkbox"/>
18.	Cables for communication network	10	<input type="checkbox"/>
19.	Telephone line	10	<input type="checkbox"/>
20.	Operational processor/chemicals	10	<input type="checkbox"/>
21.	Plates	10	<input type="checkbox"/>
22.	Storage space for plates	10	<input type="checkbox"/>
23.	Densitometer for plates/press sheet	10	<input type="checkbox"/>
24.	Provide Scitex engineer with requested punch configuration.	attached punch forms	<input type="checkbox"/>

Space Requirements

Floor Space

The minimum required floor space depends on the **Lotem 800V** configuration at your site. For example, does the configuration include an On-line processor or is the Platesetter connected to a Plate stacker that collects the exposed plates.

See the attached diagrams for detailed dimensions of the **Lotem 800V** configuration (at the end of the document).

Note: It is recommended that the Operation monitor be located to the right of the Platesetter, as shown in the figure.

Weight Requirements

- **Lotem 800V** weight - 900 kg (1980 lb.); the Platesetter rests on four (4) symmetrically-placed legs. A *Fork lift*, capable of lifting this weight, is used to lift the Platesetter packaging, and then lift the Platesetter from its shipping pallet.

Note: The Platesetter packaging should be lifted **only** from one side, as clearly marked by the label on the packaging. The Platesetter should be lifted from the shipping pallet **only** at the designated locations, clearly marked on the Platesetter chassis.

- Floor should be able to support a point load of 50 kg/cm².
- Cassette weight - 25 kg (55 lb.); when 100 8-Up plates are loaded in the Cassette, its weight increases to 120 kg (264 lb.)
- Transformer (for countries that do not have 3 phase 110V); weight - 100 kg (220 lb.)

Electrical Requirements

General Considerations

The total power consumed by your system is determined by the selected system configuration. Remember to allow sufficient margin for system expansion when calculating the required electrical capacity.

Prior to connecting the electrical power supply, ensure that all voltage settings, fuses and cords are in full accordance with local standards.

Power Line

- Line voltage at the customer's site - 208V/120V $\pm 10\%$, 3 phase (Star) 20A, 7.5 KW.

The connector to be supplied by the customer (male & female). The electrician at the customer's site should connect the three-phase R.S.T according to the three-phase sequence of the connector on the Platesetter power cable. The customer should have a 5-pin connector - 3 phase R.S.T, Neutral & GND, 32A for 120V line voltage (NEMA L21-30P), and 16A for 220V line voltage.

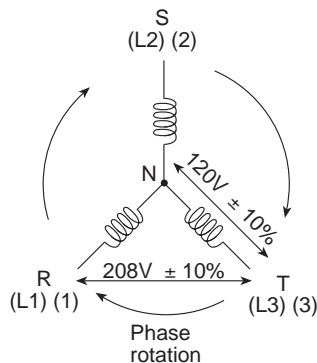

- Voltage variations of up to $\pm 10\%$ on all selectable voltages are acceptable. Supply frequency variations of ± 2 Hz are acceptable.
- When the line power supply at your site is 200-240V, the use of a step-down transformer is required.
- Power supply for Brisque + Operation monitor - 120V $\pm 10\%$ or 220V $\pm 10\%$
- Frequency - 50/60 $\pm 2\%$
- For countries with a line power of 220V - a step-down transformer is used, from 346/200, 380/220 or 415/240 to 208/120V (3 phase). The transformer can be purchased from Scitex.
Transformer - height 550 mm (22 inch), width 320 mm (12.5 inch), length 520 mm (20.5 inch).
The wall connector must have a 3 pole protection fuse, within it a circuit breaker with high transient currents (for LV/LV transformers) for 16A magnetic releases operating between 10-14 In (startup current).
- An additional isolated single phase 110V outlet is required for service purposes.
- Additional power is required for the **Processor**, **Pre-heat ovens**, **Baking ovens**, and/or **Plate stacker**. Refer to vendor's specifications, and see *Appendix A, Table 2*.

Power Line Disturbances

The reliable operation of computer systems depends on the availability of relatively noise-free AC power.

Lighting, line faults, or power switching, commonly found in machinery or equipment in office or factory environments, can generate line transients which far exceed the peak value of the applied voltage. If not attenuated, these micro-second pulses can disrupt system operation. The use of a power stabilizer is highly recommended in such cases.

Grounding

At 60 Hz sites, 110 VAC and 208 VAC grounds tied by AWG #1 solid copper wire to the main power ground point of the building.

At 50 Hz sites, 220 VAC and 380 VAC grounds, tied by 40 mm solid copper wire (7 mm in diameter) to the main power ground point of the building,

Grounding requirements for the **Lotem 800V** - and all equipment communicating with it - should be observed to ensure trouble-free operation.

Grounding requires the following:

- Grounding wires that are insulated and at least equal in size to the phase conductors.
- Ground impedance less than 2 Ohms.
- A single point and dedicated ground.
- Power stabilizer equipment that is supplied by three (3) uninterrupted phase wires, and one uninterrupted copper ground wire from the main building entry service panel. These should run in the same conduit and be at least equal in size to the phase wires.
- Neutral and ground are bonded together in the main building entry service panel, and a good earth ground at this point of not more than 2 Ohms impedance.
- Each system load (such as Platesetter, Host) is fed through an isolated ground outlet and has a separate ground, as well as neutral and phase line of equal size wire.

Note: Chained neutrals and grounds are not permissible.

Cable Protections

Preparation of proper cable protection for the cables connecting the **Lotem 800V** and the Operation monitor.

Maximum distance between the **Lotem 800V** and Operation monitor - 4.5 meter (13.5 feet).

Environmental Conditions

Cleanliness

Filters in the air conditioning system should be able to block 60% of all 10 micron dust particles.

Static Electricity

- Humidity must be 55% \pm 5% to reduce the static electricity with the plates (low humidity can cause plate and paper jamming). See *Humidity* below.
- Use of floor carpeting is not recommended in the **Lotem 800V** area. If carpets are used, only anti-static carpets should be installed at the site. The carpet thickness should be up to 0.5 inch (12 mm).

Humidity

An industrial steam humidifier is required to sufficiently meet the humidity specified for the area in which the Platesetter resides (relative humidity of 55% \pm 5%).

Air Conditioning

Sufficient air conditioning should be present to provide heat dissipation for the Platesetter, **plus** all additional equipment residing in the system room, and an additional minimum 25% safety margin.

The Platesetter requires a constant temperature of 23°C \pm 2°C (73.5°F \pm 3°F)

To calculate the air conditioning requirements for the Lotem 800V configuration at your site (in BTU/hour), see the tables below.

Basic configuration:

Platesetter	12,000-16,000 BTU/hour
Host	2,500 BTU/hour
Other Misc.	1,500 BTU/hour
Safety margin (25% of above)	6,250 BTU/hour
Total	22,250-26,250 BTU/hour

Additional optional devices

(fill in as required - see *Appendix A, Table 2* for a complete site configuration):

Pre-heat convection oven	BTU/hour
Plate processor	BTU/hour
Post-bake oven	BTU/hour
Bake conveyor	BTU/hour
Rinse/Gum unit	BTU/hour
Plate stacker	BTU/hour
Safety margin	BTU/hour
Total of Basic (previous)	22,250-26,250 BTU/hour
Total	BTU/hour

Note the following guidelines:

- It is recommended that the air flow in the system room be maintained above the normal air pressure, in order to prevent dust from entering the room.
- The system room should ideally contain both a thermometer and a hygrometer, permanently mounted in a central location.
- In addition, it is highly recommended that you have a humidity and temperature recorder.

Other Conditions

Some plates, such as *Kodak IDTP*, are sensitive to UV light. When such plates are used and the **Lotem 800V** is directly connected to the Plate stacker, you need to use an appropriate safe light.

Air Compressor Requirements

- Must be oil free compressed air line
- Operating pressure - 8 ATM (100 psi)
- Flow rate - minimum 3 CFM
- If you do not have an air compressor on your site, the recommended compressor for the **Lotem 800V** is approximately 1.5 HP, with a vessel (tank) volume of at least 12 gallons.
- The compressor outlet connector should be mounted on the wall, up to 5 meter from the Platesetter.
- Compressor outlet connector type - standard M12 female, or standard 1/2" NPT female, or quick industrial connector.

Network/Modem Requirements

- Two (2) network RJ-45 (twisted pair) sockets:
 - one socket near the Lotem 800V to connect the Lotem PC Controller to the network.
 - one socket near the Brisque.
- A direct dedicated telephone line for remote support via modem (modem is supplied with the Brisque). The modem will serve the Brisque and the Lotem via T-switch.
- Two twisted-pair cables for network connectivity - for the Lotem and the Brisque (supplied by customer).
- For improved system productivity, it is recommended that you prepare a 100BaseT network.

Processor Specifications

The processor specifications may vary and depend on the specific processor used at the customer's site. The processor vendor should provide the relevant information.

Plates

- The Lotem 800V supports thermal plates, that are sensitive to IR 830 nm wavelength.
- Storage room for plates; please consult the plate vendor for the recommended humidity and temperature ranges in which the plates should be stored.
Note: All plates are sensitive to static electricity that may cause double feeding and jamming if the humidity is out of range.
- Consult your vendor regarding a Plate densitometer that is adequate for thermal media.

APPENDIX A - CUSTOMER CONFIGURATION REQUIREMENTS

The Customer is fully responsible for contacting the vendors and obtaining all the necessary installation information.

Table 1 - Space Requirement

To calculate the total length requirements of your site, please fill out the *Customer configuration length* column in the table below. This column should reflect the configuration of the devices that you are adding to the **Lotem 800V** configuration.

Mark here	Device	Length (for reference only)	Customer configuration length
✓	Sufficient Space for loading Cassette	1000 mm (39")	1000 mm (39")
✓	Loading Cassette	1000 mm (39")	1000 mm (39")
✓	Lotem 800V	1370 mm (53")	1370 mm (53")
	Scitex Plate Conveyor	1100 mm (39")	
	Pre Heat Convection Ovens	See vendor's specifications	
	Plate Processor	See vendor's specifications	
	Bake Oven	See vendor's specifications	
	Bake Conveyor	See vendor's specifications	
	Rinse/Gum Unit	See vendor's specifications	
	Plate Stacker	See vendor's specifications	
			Total

Table 2 - Power Requirements

Table 2 is for reference purposes only. To prepare your site, please contact your vendor and obtain all the necessary information. Then fill in the necessary values in the *customer config.* columns.

Mark here	Device	Power Requirement		Heat Dissipation (in BTU/hour)	
		ref values	customer config.	ref values	customer config.
√	Lotem 800V	110V, 3 phase 6KW		12,000-16,000	
√	Brisque + Operation monitor	110V - 220V, one phase		2,500	
	Pre Heat Convection Ovens	See vendor's specifications		See vendor's specifications	
	Plate Processor	See vendor's specifications		See vendor's specifications	
	Bake Oven	See vendor's specifications		See vendor's specifications	
	Bake Conveyor	See vendor's specifications		See vendor's specifications	
	Rinse/Gum Unit	See vendor's specifications		See vendor's specifications	
	Plate Stacker	See vendor's specifications		See vendor's specifications	
			Total ⇒		

LOTEM-800V WITH KODAK CONFIGURATION

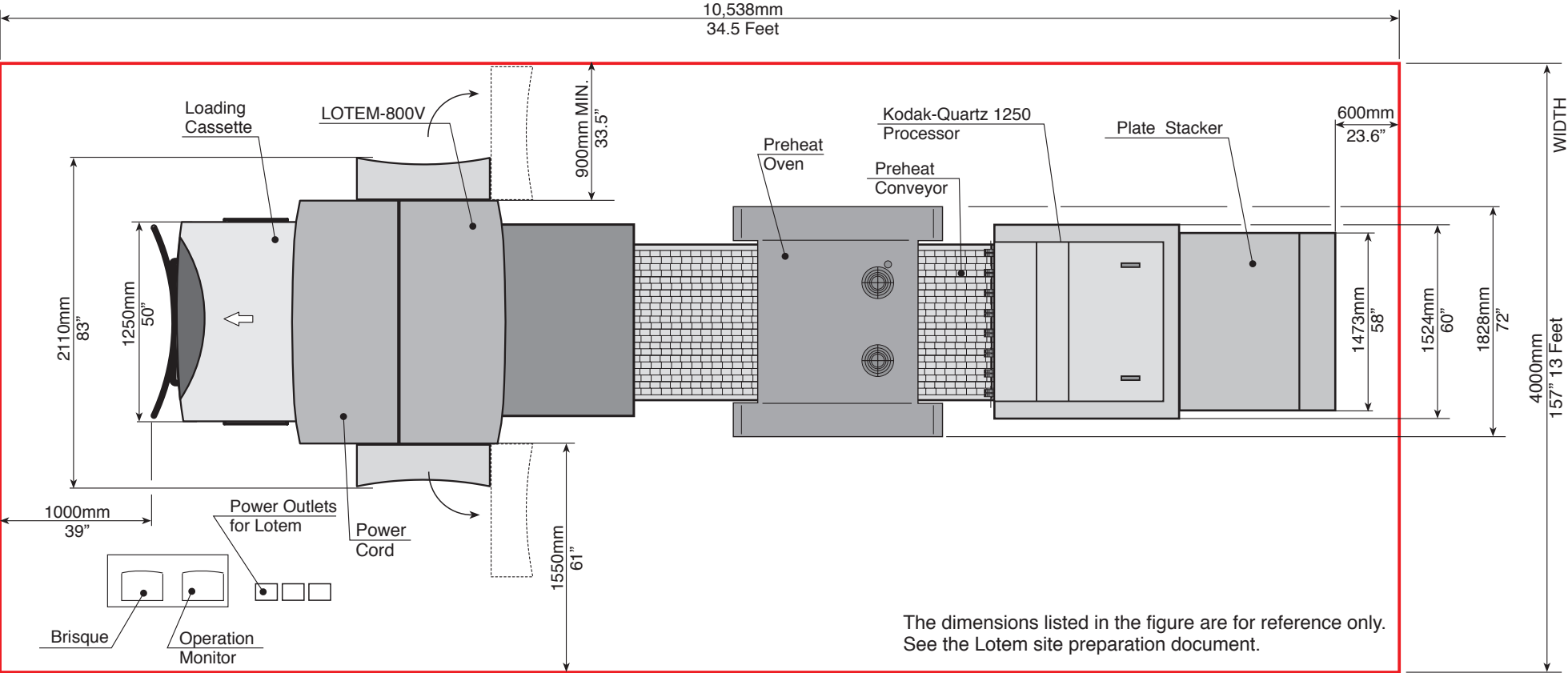
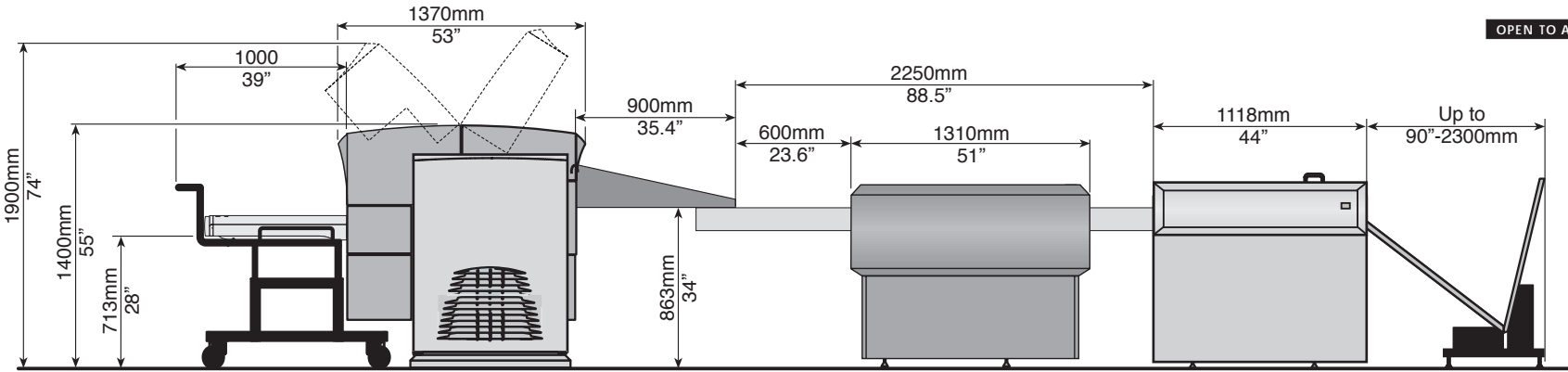

The dimensions listed in the figure are for reference only. See the Lotem site preparation document.

LOTEM-800V WITH HORSELL CONFIGURATION

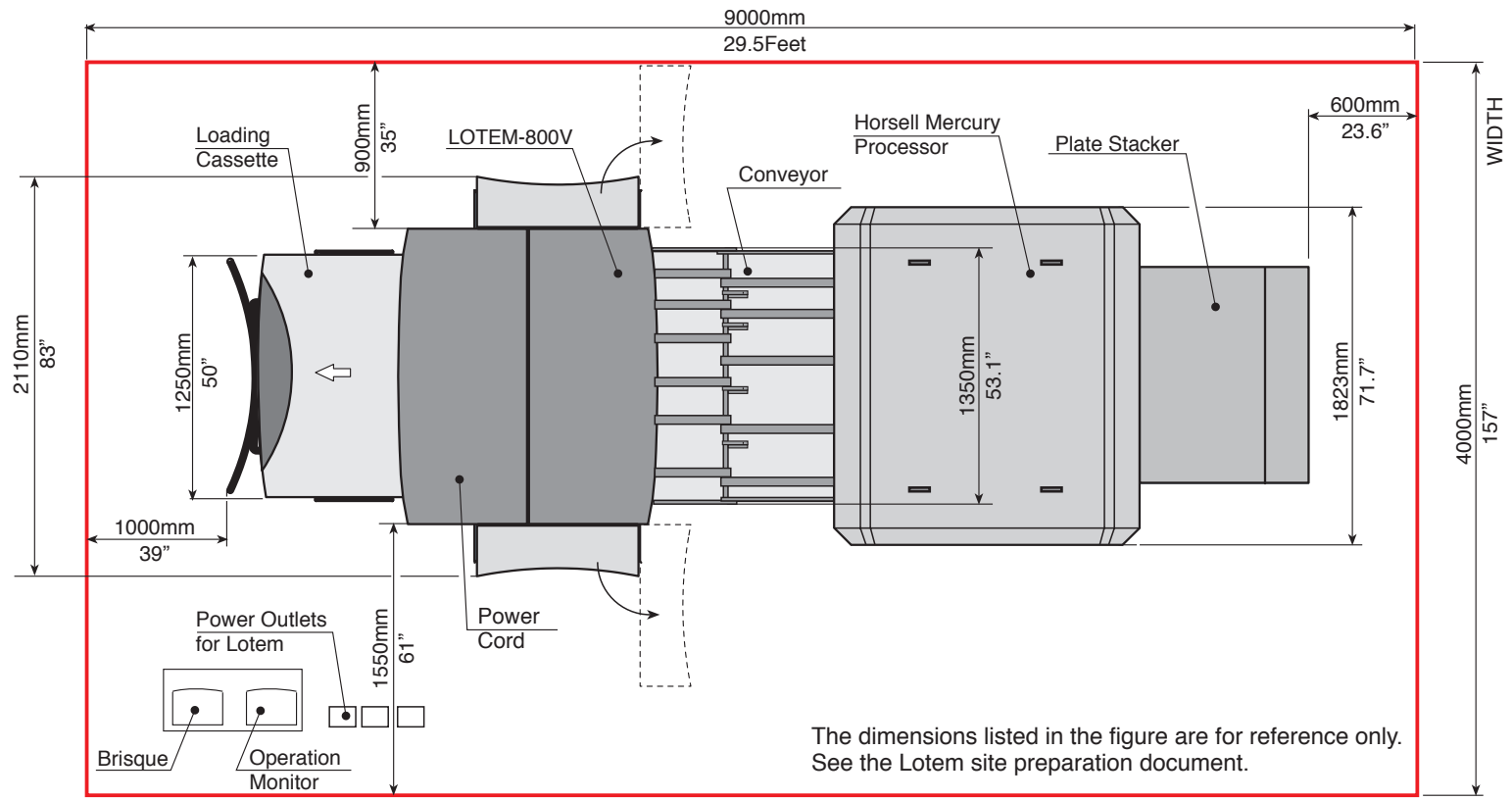
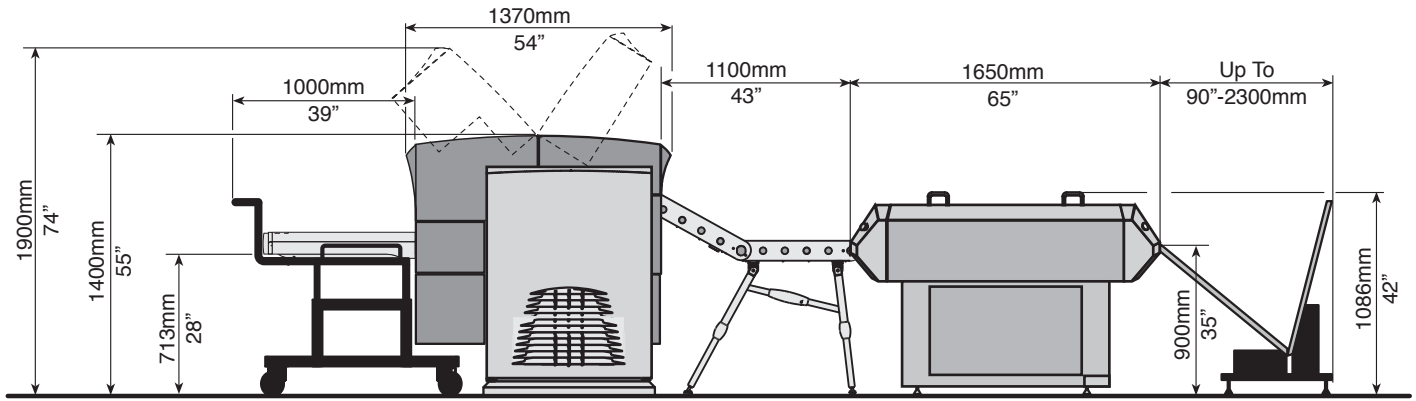

The dimensions listed in the figure are for reference only. See the Lotem site preparation document.

Mark hear		Punch edge		Punch configuration	
Qty.	P/N	Qty.	P/N		
Qty.	510K51001	Qty.	510K51227	11mm	<p>A = 425mm = 16.732" → 4UP B = 780mm = 30.708" → 8UP</p>
P/N	510K51001	P/N	510K51227		
A <input type="checkbox"/> B <input type="checkbox"/>					
Qty.	510K51227	Qty.	510K51227	11mm	<p>A = 508mm = 20" → 4UP B = 780mm = 30.708" → 8UP</p>
P/N	510K51227	P/N	510K51227		
A <input type="checkbox"/> B <input type="checkbox"/>					
Qty.	510K51125	Qty.	510K51143	9mm	<p>A = 550mm = 16.732" → 4UP B = 830mm = 30.708" → 8UP</p>
P/N	510K51125	P/N	510K51143		
A <input type="checkbox"/> B <input type="checkbox"/>					
Qty.	510K51127	Qty.	510K51127	11mm	<p>A = 508mm = 20" → 4UP B = 780mm = 30.708" → 8UP</p>
P/N	510K51127	P/N	510K51127		
A <input type="checkbox"/> B <input type="checkbox"/>					
Qty.	510K51227	Qty.	510K51227	11mm	<p>A = 425mm = 16.732" → 4UP B = 780mm = 30.708" → 8UP C = 860mm = 33.858" → 8UP</p>
P/N	510K51227	P/N	510K51227		
A <input type="checkbox"/> B <input type="checkbox"/> C <input type="checkbox"/>					
Qty.	510K51236	Qty.	510K51237	15mm	<p>A = 458mm = 18" → 4UP B = 737mm = 29" → 8UP</p>
P/N	510K51236	P/N	510K51237		
A <input type="checkbox"/> B <input type="checkbox"/>					
Qty.	510K51222	Qty.		3.175mm	<p>A = 762.5mm = 29.92" → 8UP</p>
P/N	510K51222	P/N			
A <input type="checkbox"/> B <input type="checkbox"/>					
Qty.	510K51230	Qty.	510K51231	11mm	<p>A = 400mm = 15.74" → 4UP B = 700mm = 27.55" → 8UP</p>
P/N	510K51230	P/N	510K51231		
A <input type="checkbox"/> B <input type="checkbox"/>					
Qty.	510K51221	Qty.		15mm	<p>A = 400mm = 15.74" → 4UP B = 800mm = 31.5" → 8UP</p>
P/N	510K51221	P/N			
A <input type="checkbox"/> B <input type="checkbox"/>					

Customer name:

Tel: Fax:

Scitex Rep:

Tel: Fax:



LOTEM 800V - PUNCH & PLATE CONFIGURATION ORDER FORM

	Press Type & Model	Plate Size Height	Plate Size Width	Plate Size Thickness	Print Area	Punch Pitch	Punch Edge	Pin Type	
								P/N	Qty.
4-Up									
8-Up									
4-Up									
8-Up									

Plate size: max width - 1130 mm, min width - 650 mm
 Plate size: max height - 900 mm, min height - 550 mm
 Min distance between center punches - 30 mm, max punch edge - 21mm
 Punch pitch of 612 +/-15 mm cannot be implemented.

Important Notes:

1. For each required plate format, fill in the appropriate details in the above table.
2. Specify units of measurement (mm are preferred).
3. Select pin type from the Standard Punch Configurations, and specify relevant P/N and Qty.
4. If your punch type does not appear in the Standard Punch Configurations, please draw the punch (including dimensions) in the area marked B - Custom Punch Drawing, or send a punched Plate to your Scitex representative.

Please define only the relevant press and bending punch holes.

Customer signature:

Date:

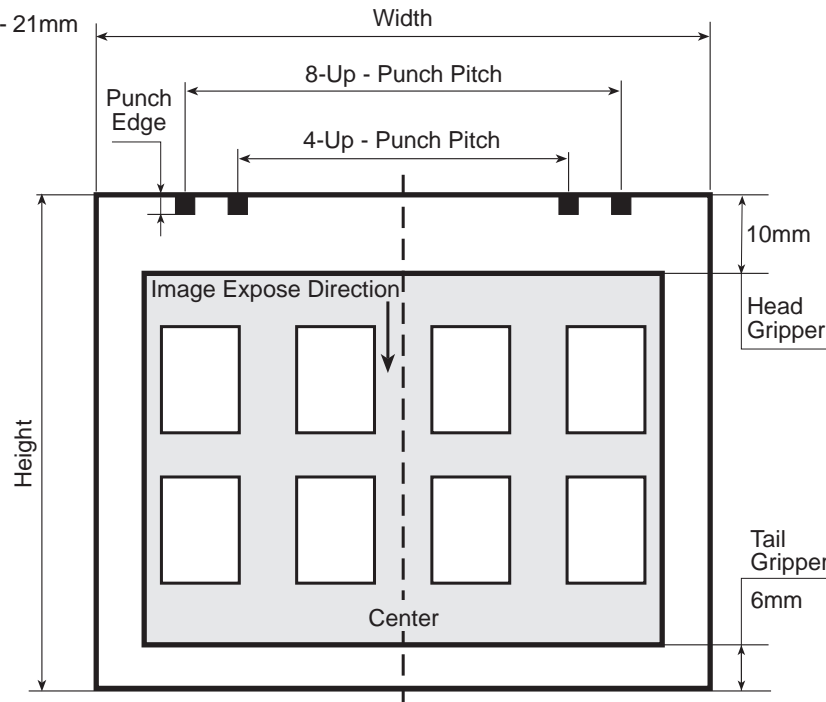

B Customized Punch Drawing